



**SHINING  
STAR**



SOLAR GARDEN LIGHT



# INTRODUCTION

Product specifications

01 FRONT COVER

02 CATALOG

03  
~  
04 MAIN  
ADVANTAGES

05 SPECIFICATIONS

06  
~  
07 DIMENTION  
FIGURE

8 MORE DETAILS

9 CORE  
TECHNOLOGY

10  
~  
11 PACKAGE  
DETAIL

12 APPLICATION



## SOLAR GARDEN LIGHT

ILLUMINATE YOUR SECRET GARDEN



# Product Advantage

ALS Technology Guarantees 10 Continuous Working Nights  
TCS Technology Ensures Longer Battery Lifespan



Can customize the temperature color  
Warm White LED, More Decorative



Solar Power, Wireless

<b>Item :</b>	ESL-15PRO	ESL-25PRO
Light Brightness	100lumens	100lumens
<b>Solar panel</b>		
Power	Monocrystalline , 5V/1.9W	Monocrystalline , 5V/1.9W
<b>Li-ion battery</b>		
Capacity	3.7V7.4WH 2.0AH/PC	3.7V7.4WH 2.0AH/PC
Charging/Discharging Temp	0~45°C/-20~60°C	0~45°C/-20~60°C
Charging Time	5.2H	5.2H
LED (OSRAM)	2835 24pcs	2835 24pcs
Color Temp	3000K , Ra 80+	3000K , Ra 80+
Efficiency	190lm/W	190lm/W
UV LED	-	-
<b>Performance</b>		
Lighting Time in Rainyday	>10 days	>10 days
Control Mode	Button Switch , ON/OFF Long Press 1.5s	Button Switch , ON/OFF Long Press 1.5s
Lighting Mode(Remote Control)	M1 : 100LM(5H) +25LM Till dawn	M1 : 100LM(5H) +25LM Till dawn
	M2 : 50LM Till dawn	M2 : 50LM Till dawn
Mode Indication	M1 : Red M2 : Green	
Capacity Indication	Green : ≥70% ; Orange : 30%~70% ; Red : <30%	
PIR	-	-
Core technology	ALS 2.3	
Solar Panel Autoclean	-	-
IP/IK Class	IP65	IP65
Install Height	-	-

ESL-15PRO

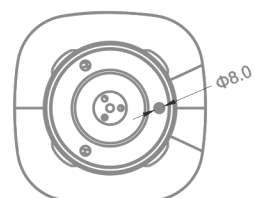
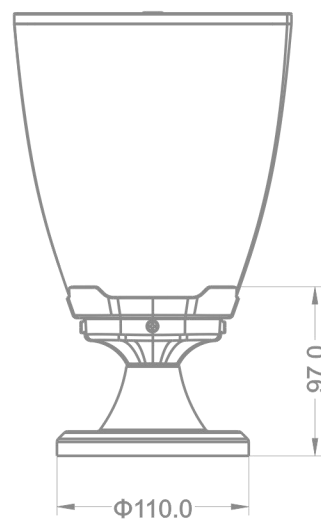
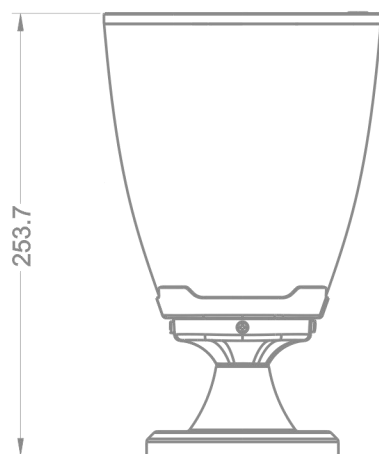
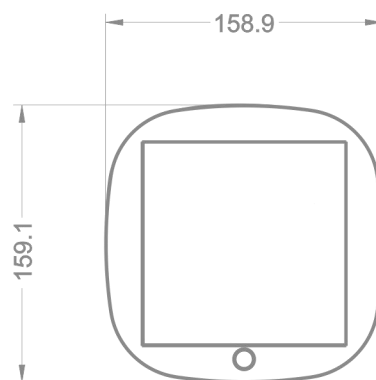

ESL-25PRO

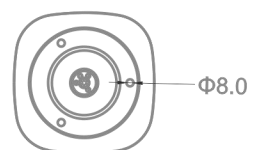
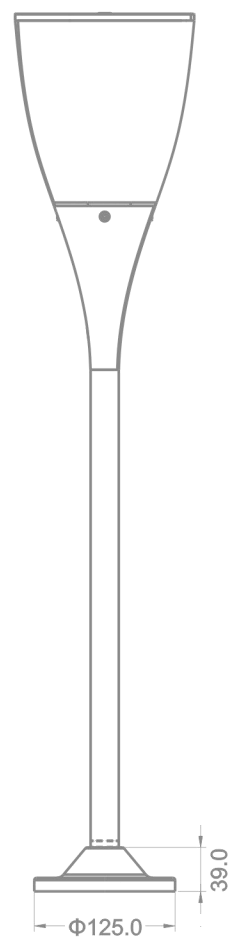
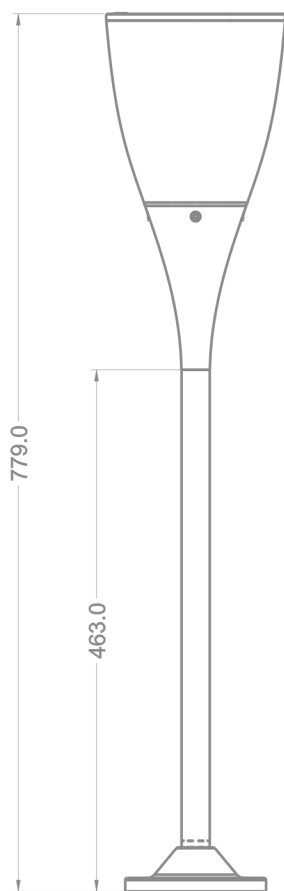
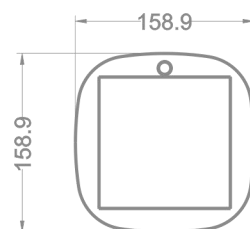

### Detail Benefits

- PC+Aluminum
- Long life span



Solar Charging Efficiency :>21%  
Switch

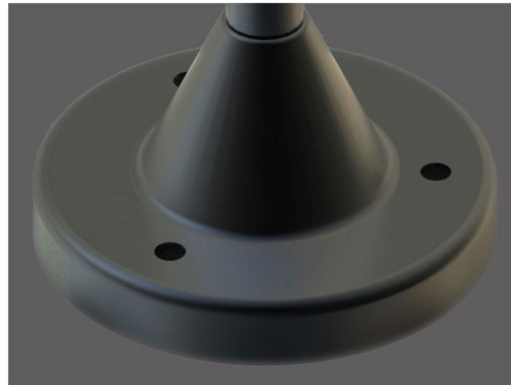

Bracket



Warm White Leds  
190lm/W



A Great Company should always pay the highest attention to the every detail design , and the craftsmanship spirit should be filled in the whole design process and mass production.



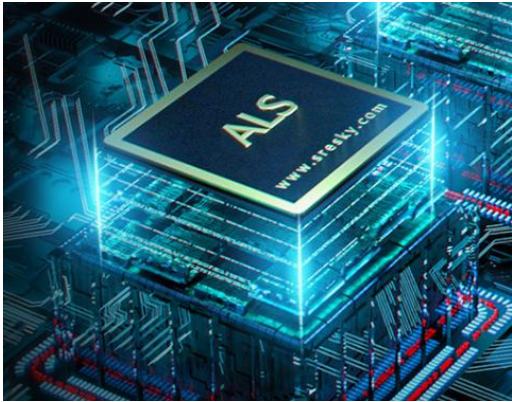

ADVANTAGE OF ALS

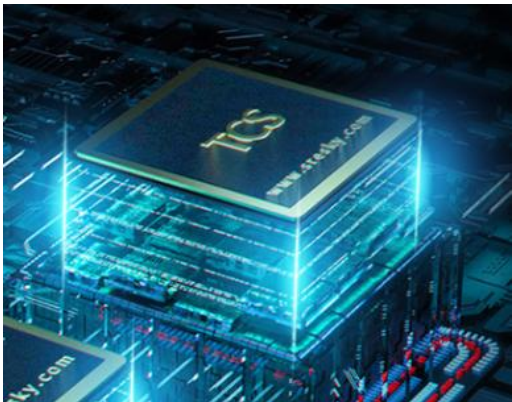
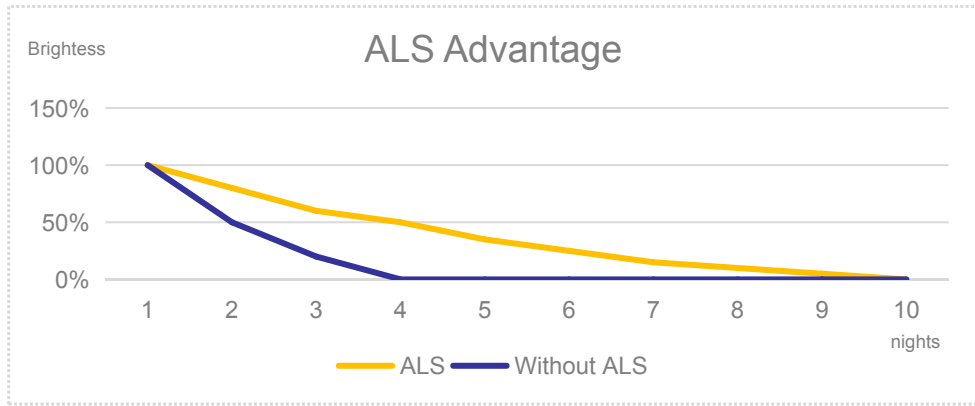

ADVANTAGE OF TCS

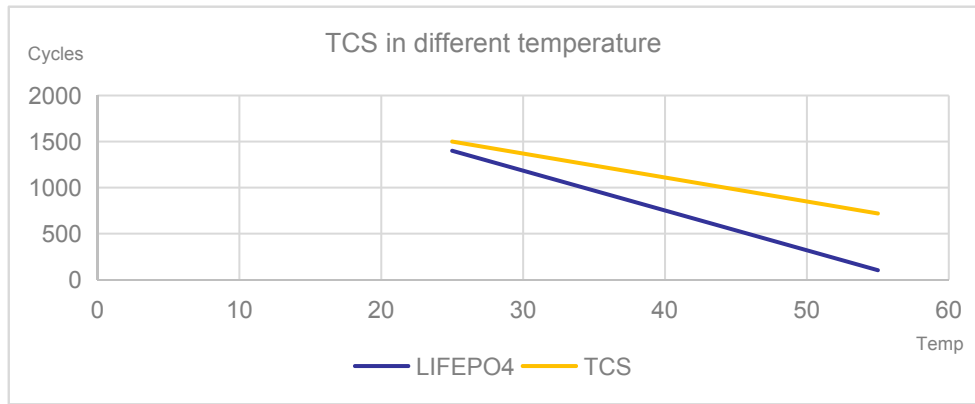

PRODUCT LIST  
PRODUCT : 1 PC



INNER BOX  
SIZE: 165\*165\*290  
1 PC / 1 BOX



1 LAYERS  
1 LAYER = 12 BOXES

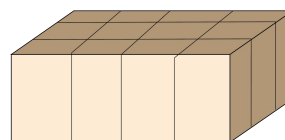

MASTER CARTON  
SIZE: 685\*515\*310mm  
12 BOXES / CTN

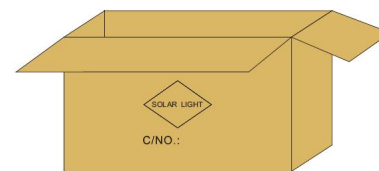

CARTON

LAYER NUMBER

COLOR BOX

PRODUCT LIST

STEP 1

STEP 2

STEP 3

STEP 4

MODEL NO.	PACKING METHOD	PCS/CTN	QTY(PCS)	CTN QTY	CARTON SIZE(MM)	N.W.(KG)	G.W.(KG)
ESL-15 PRO	INNER BOX	1	1	1	165*165*290	1	1.15
	CARTON	12	12	1	685*515*310	12	15.6

Net weight and gross weight  
are for reference only

PRODUCT LIST  
 PRODUCT : 2 PCS  
 LAMP POST : 2 PCS  
 BRACKET : 2 PCS  
 FIXATOR : 2 PCS  
 SCREW : 2 PCS

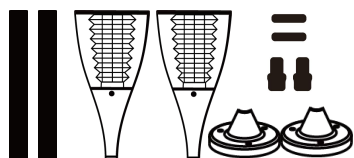

INNER BOX  
 SIZE: 380\*200\*350mm  
 2 PCS / 1 BOX



1 LAYERS  
 1 LAYER = 6 BOXES

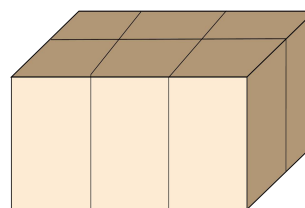

MASTER CARTON  
 SIZE: 785\*635\*370mm  
 6 BOXES / CTN  
 12 PCS / CTN

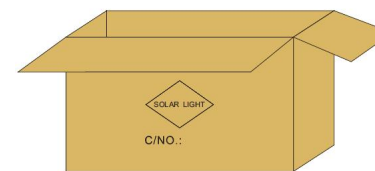

CARTON

LAYER NUMBER

COLOR BOX

PRODUCT LIST

STEP 1

STEP 2

STEP 3

STEP 4

MODEL NO.	PACKING METHOD	PCS/CTN	QTY(PCS)	CTN QTY	CARTON SIZE(MM)	N.W.(KG)	G.W.(KG)
ESL-25 PRO	INNER BOX	2	2	1	380*200*350	2.36 (2pcs)	3 (2pcs)
	CARTON	12	12	1	785*635*370	14.16	19.8

Net weight and gross weight are for reference only



S / O / L / A / R / L / I / G / H / T



THANKS  
VERY  
MUCH