



**SHINING
STAR**



Moving
Horizontally



Vertical
Sliding

MARS 2

SOLAR WALL LIGHT

INTRODUCTION

Product specifications

01 FRONT COVER

02 CATALOG

03 MAIN
ADVANTAGES

04 OTHER
ADVANTAGES

05 SPECIFICATIONS

06 OPTICAL
FIGURE

07 DIMENTION
FIGURE

08 MORE DETAILS

09 CORE
TECHNOLOGY

10 PACKAGE DETAIL

11 APPLICATION



2000LUMENS SUPER BRIGHT
EMERGENCY SOLAR WALL LIGHT

Scientific Light Distribution



Product Advantage

Fixture Head 4 Directions Adjustable
(up/down/Right/Left) for Larger Lighting Area



Vertical sliding

**DO AS YOU WISHES,
AMAZING LIKE A MAGIC CUBE.**



Moving Horizontally



Item : SWL-12

Light Brightness	2000 lumens
------------------	-------------

Solar panel

Power	Epoxy Mono-Crystalline , 4.86V/1W
-------	-----------------------------------

Li-ion battery

Capacity	3.7V 14.8WH 2AH/PC
----------	--------------------

Charging/Discharging Temp	0~45°C/-20~60°C
---------------------------	-----------------

Charging Time	10H
---------------	-----

LED (OSRAM)	2835 39pcs ;
-------------	--------------

Color Temp	4000K , Ra 80+
------------	----------------

Efficiency	190lm/W
------------	---------

UV LED	-
--------	---

Performance

Lighting Time in Rainyday	>10days
---------------------------	---------

Control Mode	Button Switch , ON/OFF Long Press 1.5s
--------------	--

Lighting Mode	M1 : 50+PIR (2000 lm) / M2 : 0+PIR (2000 lm) /M3:50lm Till dawn
---------------	---

	-
--	---

Mode Indication	M1 : Flash for one time , M2 : Flash for two times ; M3 : Flash for three times
-----------------	---

Capacity Indication	-
---------------------	---

PIR	120° , >5m
-----	------------

Core technology	ALS 2.1 / TCS 1.0
-----------------	-------------------

Solar Panel Autoclean	-
-----------------------	---

IP	IP65
----	------

Install Height	3m
----------------	----

Road Simulated Diagram

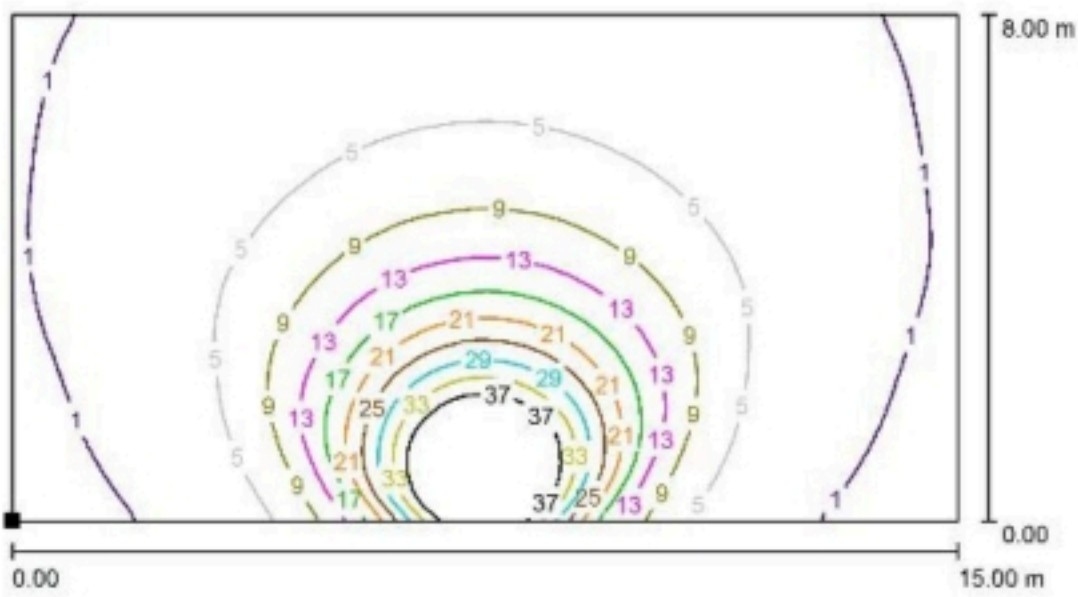

Illumination Curve

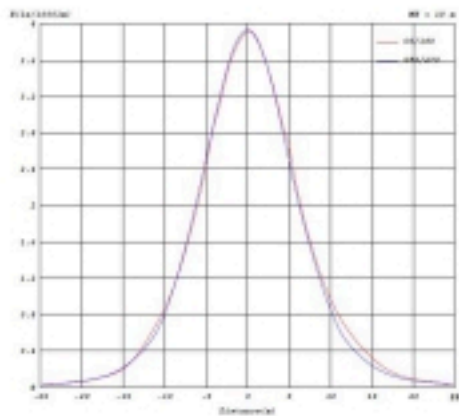

Luminance Distribution

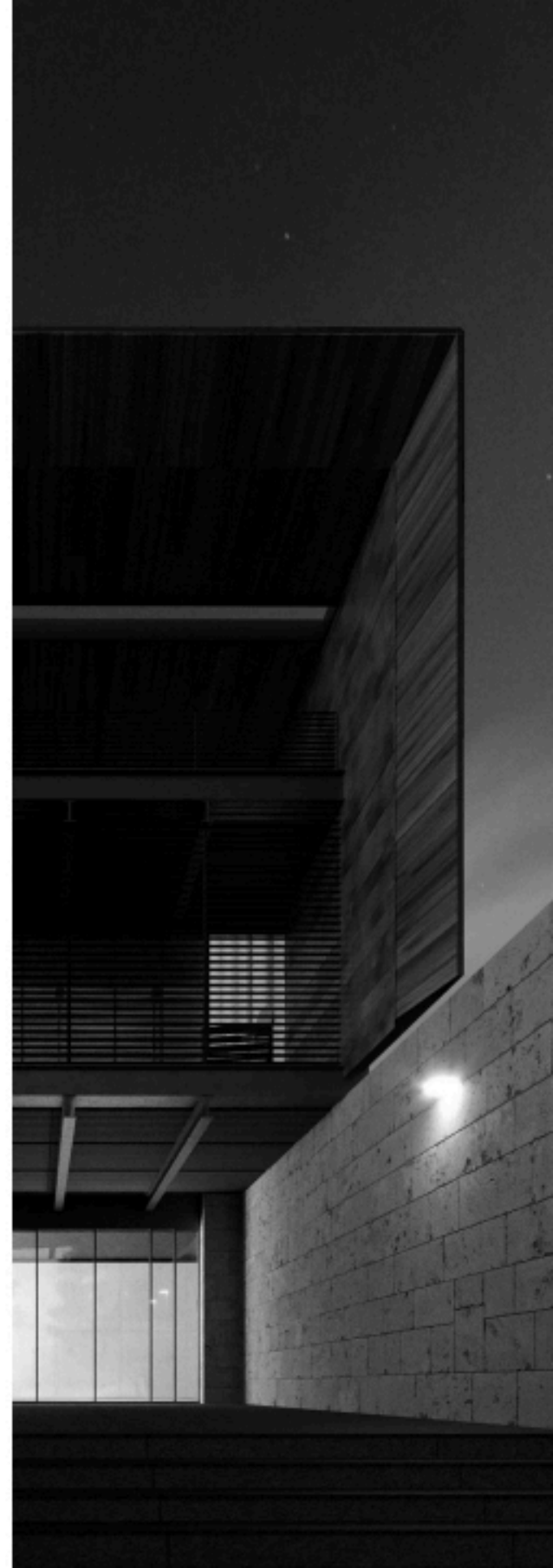
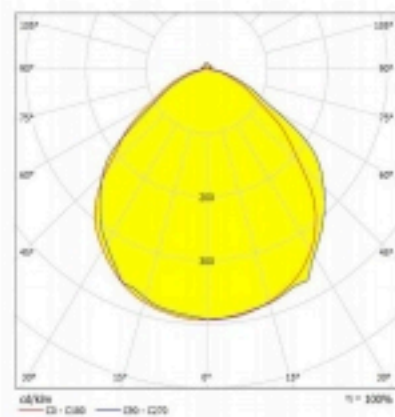

SOLAR LIGHT I DIMENSION FIGURE

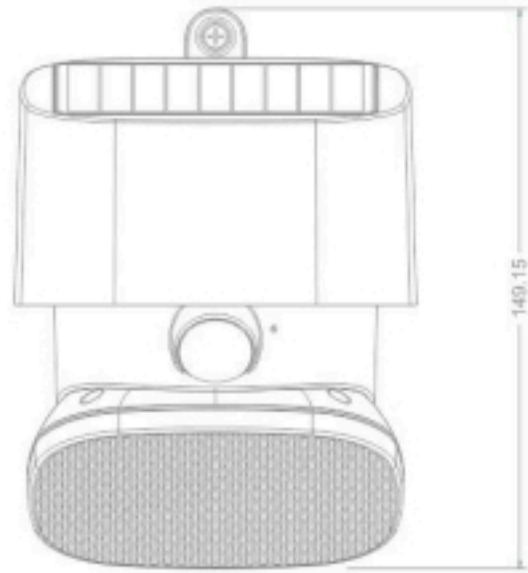
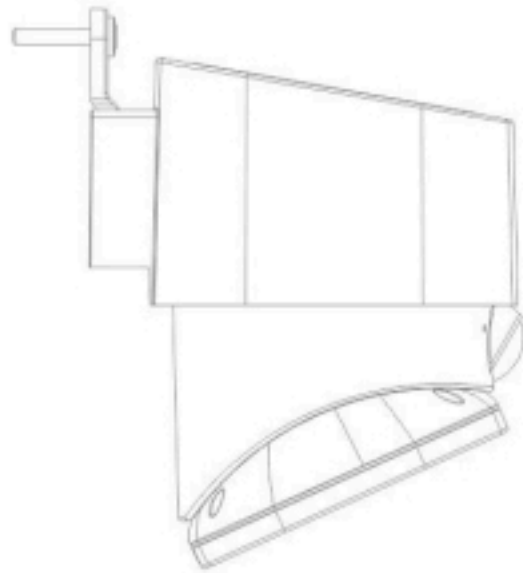

Advantage in every detail

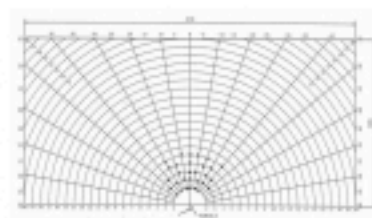

Monocrystalline
Solar Charging Efficiency :>21%

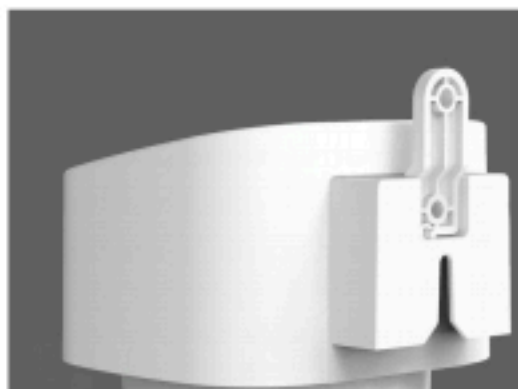

Easy to install



High sensitivity PIR sensor
Switches



Vertical sliding

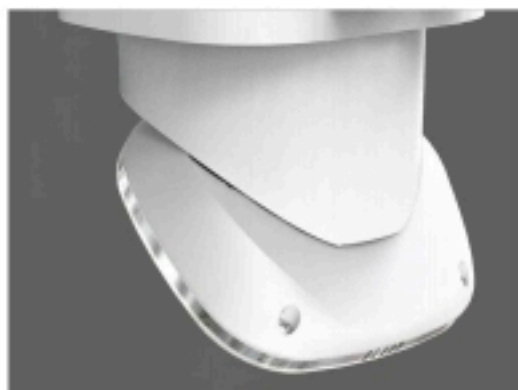

Back details

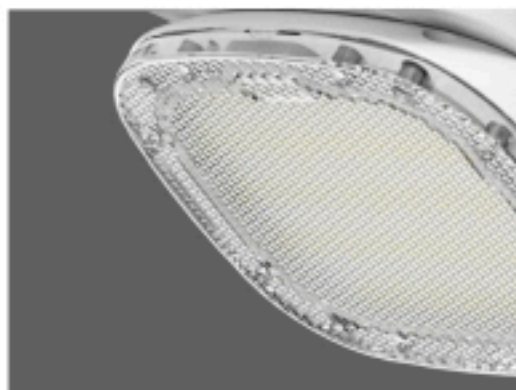

High lumen LEDs
190lm/W



A Great Company should always pay the highest attention to the every detail design , and the craftsmanship spirit should be filled in the whole design process and mass production.

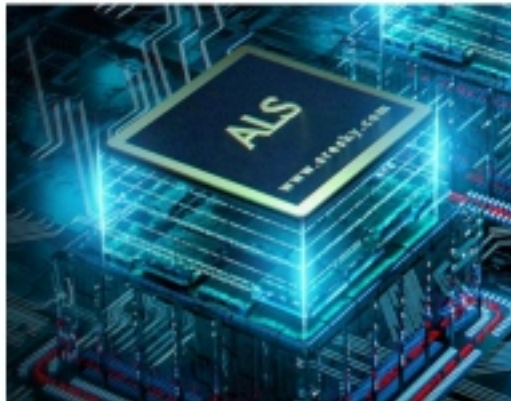

ADVANTAGE OF ALS



ADVANTAGE OF TCS

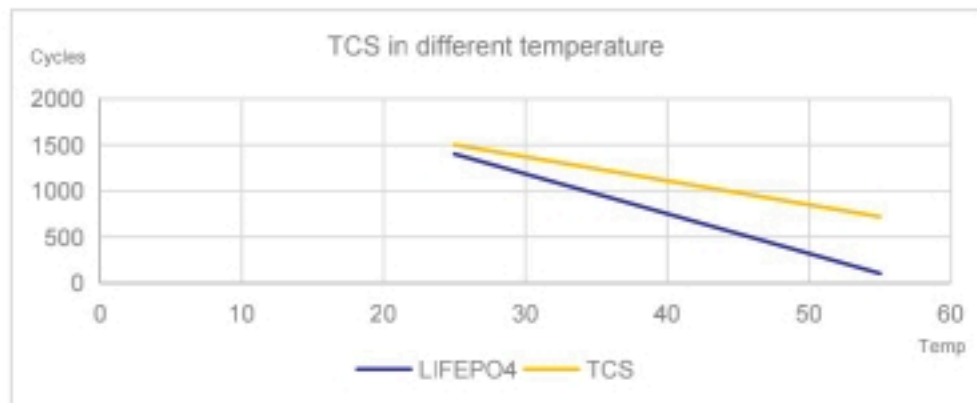

PRODUCT LIST
 SCREW : 3PCS
 EXPANSION SCREWS : 2PCS
 ACCESSORIES : 1PC
 PIN: 1PC



INNER COLOR BOX
 SIZE: 113*125*140mm
 1PCS/1 BOX



2 LAYERS
 1 LAYER = 12 BOXES



MASTER CARTON
 SIZE: 467*387*298mm
 24PCS/CTN

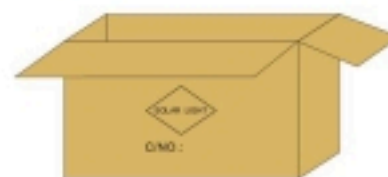

CARTON

LAYER NUMBER

COLOR BOX

PRODUCT LIST

STEP 1

STEP 2

STEP 3

STEP 4

MODEL NO.	PACKING METHOD	PCS/CTN	QTY(PCS)	CTN QTY	CARTON SIZE(MM)	N.W.(KG)	G.W.(KG)
SWL-12	COLOR BOX	1	1	1	113*125*140	0.5	0.55
	CARTON	24	24	1	467*387*298	12	12.5

Net weight and gross weight are for reference only

S / O / L / A / R / L / I / G / H / T

THANKS
VERY
MUCH

